

Stride Ruler

Use your own two feet to estimate distances.

Materials

- playground or other paved surface
- 4 metersticks
- masking tape
- pencil
- clipboard or book to create a sturdy writing surface

Group Size

whole group

Related Activity

- [Measuring and Mapping the Playground](#) 

Did You Know?

No measurement is exact. In a sense, every measurement you make is an estimate, no matter how carefully you measure. (It's been said, in fact, that while counting is difficult, measuring is impossible!)

Background

You don't always need a precise answer. A well-informed guess—an estimate—is often good enough. For example, you can estimate the time it will take you to walk to a neighborhood store and back. Your estimate may differ from the actual time by a few minutes, but it will tell you if you have time to go to the store and be back by dinnertime. Estimating distances is often useful, too, and that's what you'll find out how to do in this activity.

Try This

1. Two volunteers should lay the metersticks end to end in a straight line on the pavement, placing the 1-cm end of a meterstick against the 100-cm end of the previous one. Tape the metersticks securely to the pavement. Then tape a "start line" perpendicular to the beginning of the first meter stick. Everyone should take a turn doing the rest of the steps.

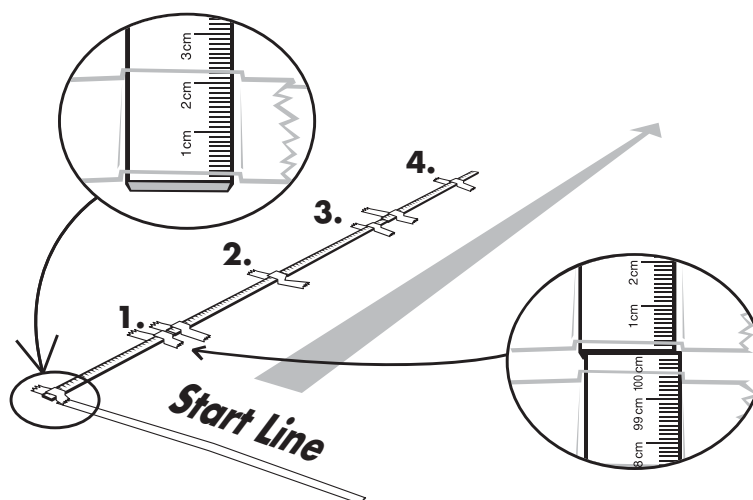

2. Put your toes just behind the "start line." Take 10 "baby steps" forward, walking right next to the line of metersticks. (When you walk in baby steps, you walk heel to toe, so that the heel of one foot touches the toes of the other foot.)

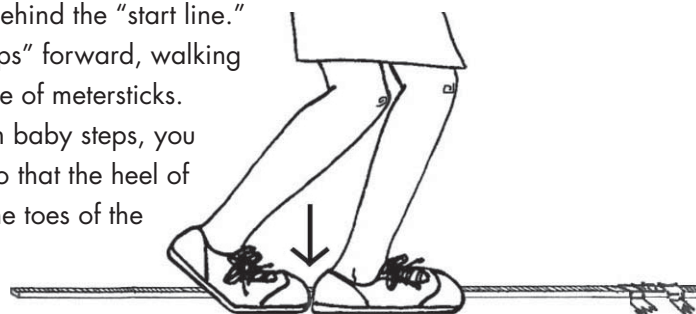

Stride Ruler (continued)

3. After your tenth step, stop and look at where the toes of your forward foot are. What's the measurement in centimeters on the meterstick? Write that number down.

Position of my toes after 10 baby steps = _____ cm

4. Look to see how many metersticks you walked past. For every meterstick you walked past, add 100 cm to the measurement in step 3. Write down your answer in centimeters.

Length of 10 baby steps in centimeters = _____ cm

5. To find the length of just one step, divide your total measurement by 10.

$\frac{\text{Length of 10 steps in cm}}{10} = \text{_____ cm}$

10

= length of 1 step in centimeters: _____ cm

Keep this number handy. You might write it down in some special place, so you can easily use your stride ruler in other activities and for purposes of your own.

6. Now you have a tool that will help you estimate the distance between any two points. Simply walk in baby steps and count your steps. Then use this formula:

**Number of baby steps × length in centimeters of 1 baby step
= distance in centimeters**

What's Going On?

Why did you have to measure 10 steps when you really wanted to know the length of 1 step? That's because if you try to measure just one step, you're likely to get a number that's a bit too big or a bit too small. By measuring 10 steps at a time, you reduce your measurement error.

Extensions

Try out your Stride Ruler by measuring the distance between different points on the playground, using the formula in step 6. (If you measure a long distance, you might want to convert your answer to meters by dividing by 100.) If someone else measures the same distance, compare your answers. It's likely that they'll be slightly different, but both will be reasonable estimates.